



Full wwPDB X-ray Structure Validation Report ⓘ

Dec 15, 2024 – 09:24 AM EST

PDB ID : 5KD7
Title : Crystal Structure of Murine MHC-I H-2Dd in complex with Murine Beta2-Microglobulin and a Variant of Peptide (PV9) of HIV gp120 MN Isolate (IGP-GRAFYYV)
Authors : Jiang, J.; Natarajan, K.; Margulies, D.
Deposited on : 2016-06-07
Resolution : 2.35 Å(reported)

This is a Full wwPDB X-ray Structure Validation Report for a publicly released PDB entry.

We welcome your comments at validation@mail.wwpdb.org

A user guide is available at

<https://www.wwpdb.org/validation/2017/XrayValidationReportHelp>

with specific help available everywhere you see the ⓘ symbol.

The types of validation reports are described at

<http://www.wwpdb.org/validation/2017/FAQs#types>.

The following versions of software and data (see [references ⓘ](#)) were used in the production of this report:

MolProbity : 4.02b-467
Mogul : 2022.3.0, CSD as543be (2022)
Xtriage (Phenix) : 1.21
EDS : 3.0
Percentile statistics : 20231227.v01 (using entries in the PDB archive December 27th 2023)
CCP4 : 9.0.004 (Gargrove)
Density-Fitness : 1.0.11
Ideal geometry (proteins) : Engh & Huber (2001)
Ideal geometry (DNA, RNA) : Parkinson et al. (1996)
Validation Pipeline (wwPDB-VP) : 2.40

1 Overall quality at a glance i

The following experimental techniques were used to determine the structure:

X-RAY DIFFRACTION

The reported resolution of this entry is 2.35 Å.

Percentile scores (ranging between 0-100) for global validation metrics of the entry are shown in the following graphic. The table shows the number of entries on which the scores are based.

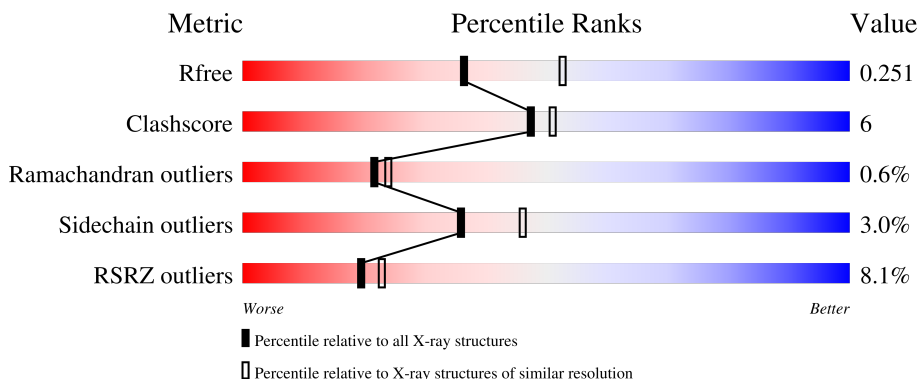

Metric	Whole archive (#Entries)	Similar resolution (#Entries, resolution range(Å))
R_{free}	164625	1460 (2.36-2.36)
Clashscore	180529	1571 (2.36-2.36)
Ramachandran outliers	177936	1559 (2.36-2.36)
Sidechain outliers	177891	1559 (2.36-2.36)
RSRZ outliers	164620	1460 (2.36-2.36)

The table below summarises the geometric issues observed across the polymeric chains and their fit to the electron density. The red, orange, yellow and green segments of the lower bar indicate the fraction of residues that contain outliers for ≥ 3 , 2, 1 and 0 types of geometric quality criteria respectively. A grey segment represents the fraction of residues that are not modelled. The numeric value for each fraction is indicated below the corresponding segment, with a dot representing fractions $\leq 5\%$. The upper red bar (where present) indicates the fraction of residues that have poor fit to the electron density. The numeric value is given above the bar.

Mol	Chain	Length	Quality of chain
1	A	275	 3% 84% 15%
1	C	275	 5% 82% 16%
1	F	275	 3% 85% 14%
1	I	275	 25% 77% 18%
2	B	100	 2% 87% 11%

Continued on next page...

Continued from previous page...

Mol	Chain	Length	Quality of chain
2	D	100	 6% 86% 13%
2	G	100	 3% 86% 14%
2	J	100	 11% 84% 15%
3	E	9	 100%
3	H	9	 67% 33%
3	K	9	 67% 33%
3	P	9	 67% 33%

2 Entry composition [i](#)

There are 6 unique types of molecules in this entry. The entry contains 12650 atoms, of which 0 are hydrogens and 0 are deuteriums.

In the tables below, the ZeroOcc column contains the number of atoms modelled with zero occupancy, the AltConf column contains the number of residues with at least one atom in alternate conformation and the Trace column contains the number of residues modelled with at most 2 atoms.

- Molecule 1 is a protein called H-2 class I histocompatibility antigen, D-D alpha chain.

Mol	Chain	Residues	Atoms					ZeroOcc	AltConf	Trace
			Total	C	N	O	S			
1	A	273	Total 2241	C 1408	N 406	O 418	S 9	0	0	0
1	C	273	Total 2244	C 1409	N 406	O 420	S 9	0	0	0
1	F	275	Total 2261	C 1420	N 412	O 420	S 9	0	1	0
1	I	266	Total 2095	C 1320	N 376	O 390	S 9	0	0	0

- Molecule 2 is a protein called Beta-2-microglobulin.

Mol	Chain	Residues	Atoms					ZeroOcc	AltConf	Trace
			Total	C	N	O	S			
2	B	99	Total 820	C 523	N 138	O 152	S 7	0	1	0
2	D	100	Total 817	C 524	N 139	O 147	S 7	0	0	0
2	G	100	Total 823	C 525	N 139	O 151	S 8	0	0	0
2	J	100	Total 809	C 520	N 133	O 148	S 8	0	0	0

There are 4 discrepancies between the modelled and reference sequences:

Chain	Residue	Modelled	Actual	Comment	Reference
B	0	MET	-	initiating methionine	UNP P01887
D	0	MET	-	initiating methionine	UNP P01887
G	0	MET	-	initiating methionine	UNP P01887
J	0	MET	-	initiating methionine	UNP P01887

- Molecule 3 is a protein called Peptide (PV9) of HIV gp120 MN isolate (IGPGRAFVY).

Mol	Chain	Residues	Atoms				ZeroOcc	AltConf	Trace
3	P	9	Total	C	N	O	0	0	0
			70	47	12	11			
3	E	9	Total	C	N	O	0	0	0
			70	47	12	11			
3	H	9	Total	C	N	O	0	0	0
			70	47	12	11			
3	K	9	Total	C	N	O	0	0	0
			70	47	12	11			

- Molecule 4 is 1,2-ETHANEDIOL (three-letter code: EDO) (formula: C₂H₆O₂).

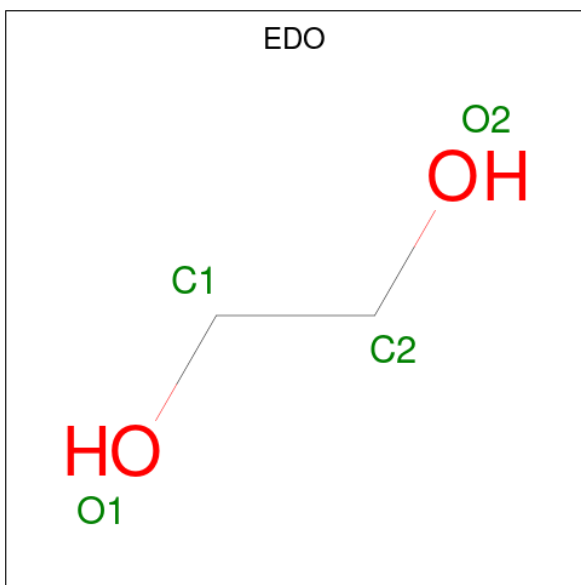

Mol	Chain	Residues	Atoms			ZeroOcc	AltConf
4	A	1	Total	C	O	0	0
			4	2	2		
4	B	1	Total	C	O	0	0
			4	2	2		
4	B	1	Total	C	O	0	0
			4	2	2		
4	D	1	Total	C	O	0	0
			4	2	2		
4	F	1	Total	C	O	0	0
			4	2	2		
4	F	1	Total	C	O	0	0
			4	2	2		
4	I	1	Total	C	O	0	0
			4	2	2		

- Molecule 5 is GLYCEROL (three-letter code: GOL) (formula: C₃H₈O₃).



Mol	Chain	Residues	Atoms	ZeroOcc	AltConf
5	F	1	Total C O 6 3 3	0	0
5	F	1	Total C O 6 3 3	0	0

- Molecule 6 is water.

Mol	Chain	Residues	Atoms	ZeroOcc	AltConf
6	A	47	Total O 47 47	0	0
6	B	28	Total O 28 28	0	0
6	P	2	Total O 2 2	0	0
6	C	42	Total O 42 42	0	0
6	D	5	Total O 5 5	0	0
6	E	2	Total O 2 2	0	0
6	F	45	Total O 45 45	0	0
6	G	30	Total O 30 30	0	0
6	H	1	Total O 1 1	0	0
6	I	10	Total O 10 10	0	0

Continued on next page...

Continued from previous page...

Mol	Chain	Residues	Atoms		ZeroOcc	AltConf
6	J	5	Total	O	0	0
			5	5		
6	K	3	Total	O	0	0
			3	3		

3 Residue-property plots [i](#)

These plots are drawn for all protein, RNA, DNA and oligosaccharide chains in the entry. The first graphic for a chain summarises the proportions of the various outlier classes displayed in the second graphic. The second graphic shows the sequence view annotated by issues in geometry and electron density. Residues are color-coded according to the number of geometric quality criteria for which they contain at least one outlier: green = 0, yellow = 1, orange = 2 and red = 3 or more. A red dot above a residue indicates a poor fit to the electron density ($RSRZ > 2$). Stretches of 2 or more consecutive residues without any outlier are shown as a green connector. Residues present in the sample, but not in the model, are shown in grey.

- Molecule 1: H-2 class I histocompatibility antigen, D-D alpha chain

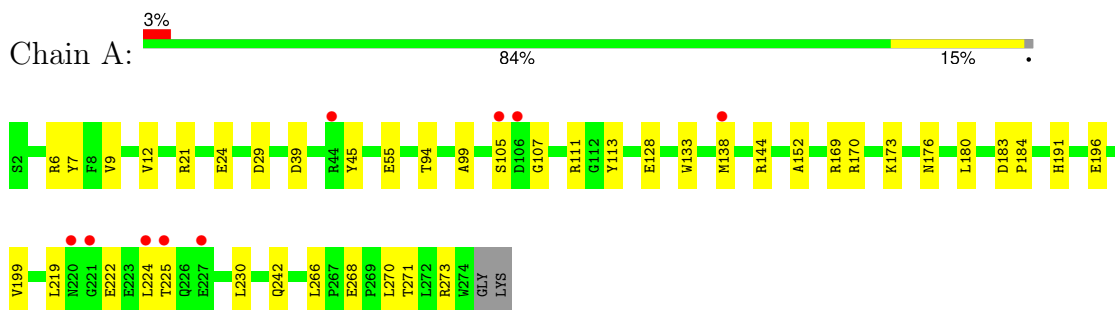

- Molecule 1: H-2 class I histocompatibility antigen, D-D alpha chain

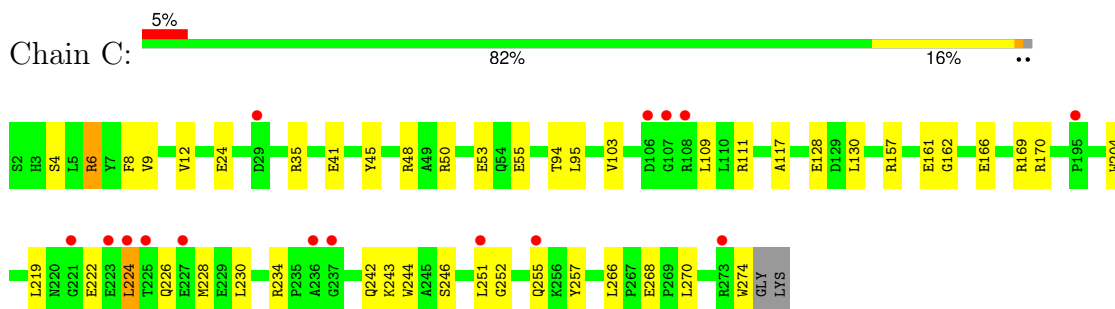

- Molecule 1: H-2 class I histocompatibility antigen, D-D alpha chain

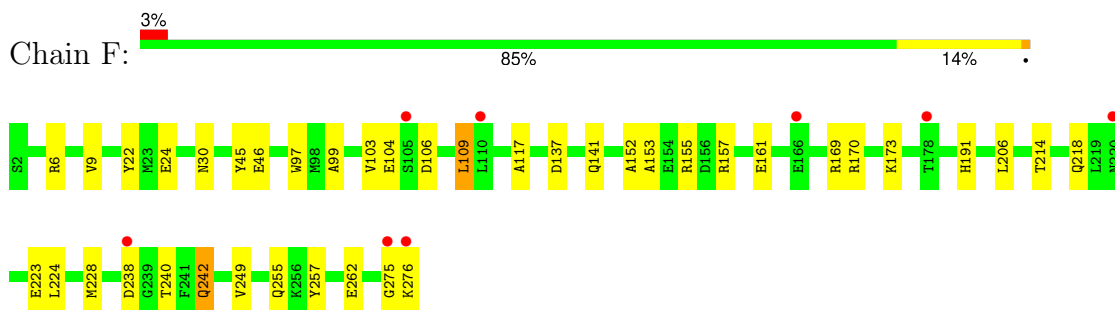

- Molecule 1: H-2 class I histocompatibility antigen, D-D alpha chain

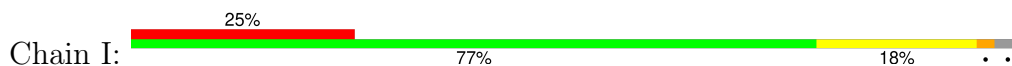

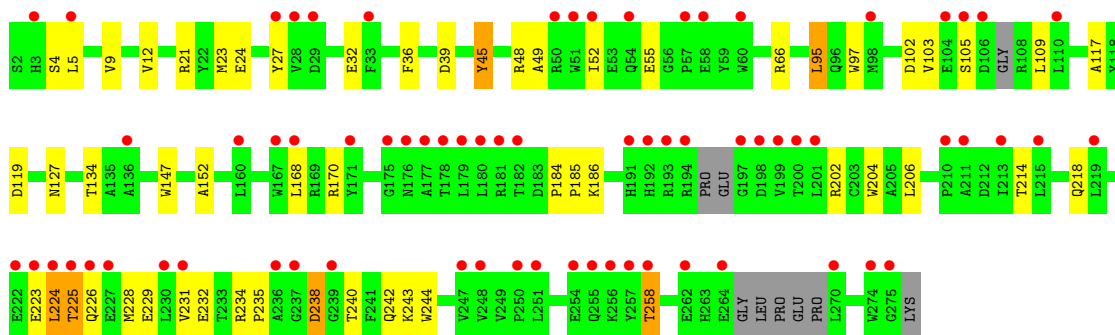

- Molecule 2: Beta-2-microglobulin

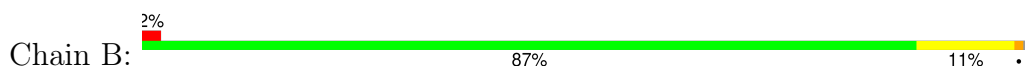

- Molecule 2: Beta-2-microglobulin

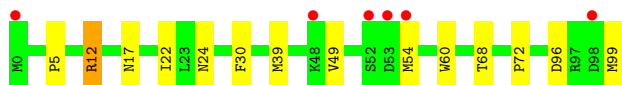
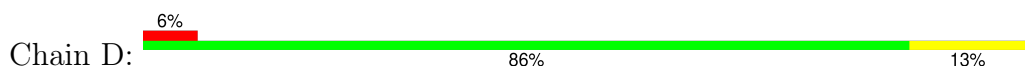

- Molecule 2: Beta-2-microglobulin

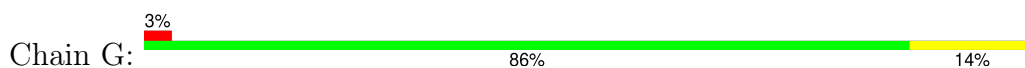

- Molecule 2: Beta-2-microglobulin

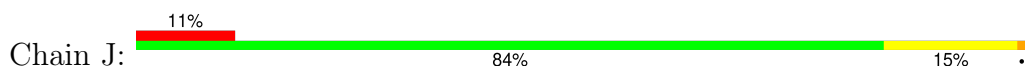

- Molecule 3: Peptide (PV9) of HIV gp120 MN isolate (IGPGRAFYYV)



- Molecule 3: Peptide (PV9) of HIV gp120 MN isolate (IGPGRAFYYV)

Chain E:  100%

There are no outlier residues recorded for this chain.

- Molecule 3: Peptide (PV9) of HIV gp120 MN isolate (IGPGRAFYYV)

Chain H:  67% 33%



- Molecule 3: Peptide (PV9) of HIV gp120 MN isolate (IGPGRAFYYV)

Chain K:  67% 33%

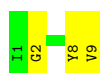

4 Data and refinement statistics

Property	Value	Source
Space group	P 1	Depositor
Cell constants a, b, c, α , β , γ	51.42Å 75.36Å 120.03Å 93.52° 87.14° 96.50°	Depositor
Resolution (Å)	42.72 – 2.35 42.72 – 2.35	Depositor EDS
% Data completeness (in resolution range)	97.8 (42.72-2.35) 97.8 (42.72-2.35)	Depositor EDS
R_{merge}	0.06	Depositor
R_{sym}	(Not available)	Depositor
$\langle I/\sigma(I) \rangle$ ¹	1.86 (at 2.34Å)	Xtrriage
Refinement program	PHENIX (1.10.1_2155: ???)	Depositor
R, R_{free}	0.198 , 0.249 0.202 , 0.251	Depositor DCC
R_{free} test set	2012 reflections (2.77%)	wwPDB-VP
Wilson B-factor (Å ²)	31.9	Xtrriage
Anisotropy	0.700	Xtrriage
Bulk solvent k_{sol} (e/Å ³), B_{sol} (Å ²)	0.30 , 45.4	EDS
L-test for twinning ²	$\langle L \rangle = 0.49$, $\langle L^2 \rangle = 0.32$	Xtrriage
Estimated twinning fraction	No twinning to report.	Xtrriage
F_o, F_c correlation	0.94	EDS
Total number of atoms	12650	wwPDB-VP
Average B, all atoms (Å ²)	52.0	wwPDB-VP

Xtrriage's analysis on translational NCS is as follows: *The largest off-origin peak in the Patterson function is 5.18% of the height of the origin peak. No significant pseudotranslation is detected.*

¹Intensities estimated from amplitudes.

²Theoretical values of $\langle |L| \rangle$, $\langle L^2 \rangle$ for acentric reflections are 0.5, 0.333 respectively for untwinned datasets, and 0.375, 0.2 for perfectly twinned datasets.

5 Model quality [i](#)

5.1 Standard geometry [i](#)

Bond lengths and bond angles in the following residue types are not validated in this section: EDO, GOL

The Z score for a bond length (or angle) is the number of standard deviations the observed value is removed from the expected value. A bond length (or angle) with $|Z| > 5$ is considered an outlier worth inspection. RMSZ is the root-mean-square of all Z scores of the bond lengths (or angles).

Mol	Chain	Bond lengths		Bond angles	
		RMSZ	# Z >5	RMSZ	# Z >5
1	A	0.33	0/2304	0.50	1/3129 (0.0%)
1	C	0.32	0/2307	0.51	0/3133
1	F	0.32	0/2327	0.51	0/3158
1	I	0.28	0/2151	0.47	0/2927
2	B	0.36	0/849	0.56	0/1151
2	D	0.33	0/843	0.53	0/1144
2	G	0.32	0/849	0.53	0/1150
2	J	0.29	0/835	0.51	0/1135
3	E	1.00	0/72	0.73	0/95
3	H	0.90	0/72	0.66	0/95
3	K	0.87	0/72	0.68	0/95
3	P	0.96	0/72	0.57	0/95
All	All	0.34	0/12753	0.51	1/17307 (0.0%)

Chiral center outliers are detected by calculating the chiral volume of a chiral center and verifying if the center is modelled as a planar moiety or with the opposite hand. A planarity outlier is detected by checking planarity of atoms in a peptide group, atoms in a mainchain group or atoms of a sidechain that are expected to be planar.

Mol	Chain	#Chirality outliers	#Planarity outliers
2	J	0	1

There are no bond length outliers.

All (1) bond angle outliers are listed below:

Mol	Chain	Res	Type	Atoms	Z	Observed(°)	Ideal(°)
1	A	230	LEU	CA-CB-CG	6.26	129.70	115.30

There are no chirality outliers.

All (1) planarity outliers are listed below:

Mol	Chain	Res	Type	Group
2	J	9	VAL	Peptide

5.2 Too-close contacts [i](#)

In the following table, the Non-H and H(model) columns list the number of non-hydrogen atoms and hydrogen atoms in the chain respectively. The H(added) column lists the number of hydrogen atoms added and optimized by MolProbity. The Clashes column lists the number of clashes within the asymmetric unit, whereas Symm-Clashes lists symmetry-related clashes.

Mol	Chain	Non-H	H(model)	H(added)	Clashes	Symm-Clashes
1	A	2241	0	2109	23	1
1	C	2244	0	2111	26	1
1	F	2261	0	2135	20	0
1	I	2095	0	1896	38	0
2	B	820	0	792	6	0
2	D	817	0	793	14	0
2	G	823	0	797	7	0
2	J	809	0	780	12	0
3	E	70	0	71	0	0
3	H	70	0	71	5	0
3	K	70	0	71	3	0
3	P	70	0	71	3	0
4	A	4	0	6	0	0
4	B	8	0	12	0	0
4	D	4	0	6	0	0
4	F	8	0	12	2	0
4	I	4	0	6	2	0
5	F	12	0	15	2	0
6	A	47	0	0	3	0
6	B	28	0	0	0	0
6	C	42	0	0	0	0
6	D	5	0	0	0	0
6	E	2	0	0	0	0
6	F	45	0	0	1	0
6	G	30	0	0	0	0
6	H	1	0	0	0	0
6	I	10	0	0	0	0
6	J	5	0	0	0	0
6	K	3	0	0	0	0
6	P	2	0	0	0	0
All	All	12650	0	11754	134	1

The all-atom clashscore is defined as the number of clashes found per 1000 atoms (including

hydrogen atoms). The all-atom clashscore for this structure is 6.

All (134) close contacts within the same asymmetric unit are listed below, sorted by their clash magnitude.

Atom-1	Atom-2	Interatomic distance (Å)	Clash overlap (Å)
4:F:302:EDO:H11	3:H:8:TYR:H	1.37	0.89
4:I:301:EDO:H11	3:K:8:TYR:H	1.41	0.83
1:C:55:GLU:OE1	1:C:170:ARG:NH1	2.17	0.77
1:A:219:LEU:HB2	1:A:224:LEU:HD11	1.68	0.75
1:A:55:GLU:OE2	1:A:170:ARG:NH1	2.22	0.72
1:I:234:ARG:NH2	1:I:235:PRO:O	2.27	0.68
1:I:103:VAL:HG12	1:I:109:LEU:HA	1.77	0.65
1:C:230:LEU:HD22	1:C:243:LYS:HE3	1.78	0.65
1:C:166:GLU:OE2	1:C:169:ARG:NH2	2.28	0.62
1:C:12:VAL:HG13	1:C:94:THR:HG22	1.82	0.61
1:I:184:PRO:O	1:I:186:LYS:NZ	2.26	0.61
1:A:169:ARG:O	1:A:173:LYS:HG2	2.00	0.61
1:I:9:VAL:HG22	1:I:24:GLU:HG2	1.83	0.60
1:A:111:ARG:HG2	1:A:113:TYR:CZ	2.37	0.59
1:F:9:VAL:HG22	1:F:24:GLU:HG2	1.83	0.59
1:I:66:ARG:HH12	3:K:2:GLY:H	1.52	0.58
1:I:234:ARG:HH11	2:J:10:TYR:HB3	1.69	0.57
1:I:223:GLU:O	1:I:225:THR:N	2.38	0.57
1:I:228:MET:HG2	1:I:229:GLU:H	1.69	0.57
4:F:302:EDO:H11	3:H:8:TYR:N	2.16	0.56
1:C:6:ARG:HG3	1:C:8:PHE:HE1	1.69	0.56
1:C:224:LEU:HD11	1:C:257:TYR:CE2	2.42	0.55
1:A:12:VAL:HG11	2:B:33:PRO:HG3	1.88	0.55
2:D:12:ARG:NH1	2:D:24:ASN:HD21	2.04	0.55
1:I:21:ARG:HH21	1:I:23:MET:HE2	1.72	0.54
1:I:48:ARG:NH2	2:J:53:ASP:OD2	2.39	0.54
1:I:5:LEU:HB2	1:I:168:LEU:HD13	1.90	0.54
1:A:12:VAL:HG23	1:A:21:ARG:HB3	1.91	0.53
1:I:224:LEU:O	1:I:226:GLN:N	2.41	0.53
2:D:12:ARG:HG3	2:D:22:ILE:HB	1.91	0.52
1:F:214:THR:HB	1:F:262:GLU:HB2	1.91	0.52
1:I:127:ASN:OD1	1:I:134:THR:OG1	2.21	0.52
1:A:12:VAL:HG12	1:A:94:THR:HG22	1.92	0.52
1:I:119:ASP:HB3	2:J:0:MET:HG2	1.92	0.52
1:F:152:ALA:HA	3:H:7:PHE:CZ	2.45	0.52
1:I:9:VAL:HB	1:I:97:TRP:HB3	1.91	0.52
2:G:36:GLU:HB2	2:G:83:LYS:HB3	1.93	0.51
1:F:157[B]:ARG:NH1	1:F:161:GLU:OE2	2.44	0.51

Continued on next page...

Continued from previous page...

Atom-1	Atom-2	Interatomic distance (Å)	Clash overlap (Å)
1:A:9:VAL:HG22	1:A:24:GLU:HG2	1.92	0.51
1:A:196:GLU:OE1	1:A:196:GLU:N	2.38	0.51
1:I:231:VAL:O	1:I:243:LYS:NZ	2.36	0.51
2:D:49:VAL:HG12	2:D:68:THR:HB	1.92	0.51
1:I:147:TRP:HB3	1:I:152:ALA:HB3	1.92	0.51
1:F:6:ARG:NH2	1:F:30:ASN:OD1	2.45	0.50
1:I:218:GLN:HB2	1:I:258:THR:HG23	1.94	0.50
4:I:301:EDO:H11	3:K:8:TYR:N	2.19	0.49
1:I:238:ASP:OD1	1:I:240:THR:HG22	2.12	0.49
1:A:111:ARG:HD2	1:A:128:GLU:HG3	1.93	0.49
1:C:266:LEU:HD13	1:C:270:LEU:HG	1.95	0.49
2:D:12:ARG:CG	2:D:22:ILE:HB	2.42	0.49
2:B:2:GLN:HA	2:B:31:HIS:O	2.13	0.48
1:C:244:TRP:HE1	2:D:99:MET:HE2	1.78	0.48
1:I:12:VAL:HG11	2:J:33:PRO:HG3	1.95	0.48
1:I:234:ARG:HD3	2:J:10:TYR:CG	2.48	0.48
2:D:39:MET:HB2	2:D:49:VAL:HG11	1.94	0.48
1:I:27:TYR:HE1	1:I:32:GLU:HB2	1.78	0.48
5:F:304:GOL:H12	2:G:12:ARG:HG2	1.96	0.48
1:C:9:VAL:HG22	1:C:24:GLU:HG2	1.96	0.48
1:C:234:ARG:HH12	2:D:99:MET:HE2	1.79	0.48
1:C:109:LEU:HD12	1:C:161:GLU:HG2	1.95	0.47
1:F:103:VAL:HG12	1:F:109:LEU:HA	1.95	0.47
1:I:21:ARG:HD2	1:I:39:ASP:OD2	2.14	0.47
1:I:49:ALA:O	1:I:52:ILE:HG22	2.14	0.47
1:I:202:ARG:HG2	1:I:204:TRP:NE1	2.30	0.47
1:A:99:ALA:HB3	3:P:3:PRO:HG3	1.95	0.47
1:I:202:ARG:HD3	1:I:244:TRP:CD2	2.50	0.47
2:J:5:PRO:HB3	2:J:30:PHE:HB3	1.97	0.47
1:A:152:ALA:HA	3:P:7:PHE:CZ	2.50	0.47
1:F:117:ALA:HB2	2:G:60:TRP:CE2	2.51	0.46
1:I:232:GLU:OE2	2:J:28:THR:OG1	2.32	0.46
1:F:249:VAL:HG22	1:F:257:TYR:CZ	2.50	0.46
1:I:27:TYR:HD1	1:I:32:GLU:HA	1.81	0.45
2:J:79:ALA:HB2	2:J:94:TYR:CD2	2.50	0.45
1:F:97:TRP:CH2	3:H:3:PRO:HG2	2.52	0.45
1:F:170:ARG:NH2	6:F:405:HOH:O	2.49	0.45
1:C:251:LEU:HD12	1:C:252:GLY:H	1.82	0.45
2:D:5:PRO:HB3	2:D:30:PHE:HB3	1.99	0.45
1:I:36:PHE:HB2	1:I:45:TYR:CD1	2.52	0.45
1:A:21:ARG:HD2	1:A:39:ASP:OD2	2.17	0.45

Continued on next page...

Continued from previous page...

Atom-1	Atom-2	Interatomic distance (Å)	Clash overlap (Å)
1:C:255:GLN:NE2	1:C:274:TRP:O	2.39	0.45
1:A:191:HIS:CD2	1:A:199:VAL:HG11	2.53	0.44
2:B:54:MET:HG3	2:B:64:ILE:HB	1.99	0.44
2:G:58:LYS:HE3	2:G:58:LYS:HB2	1.76	0.44
1:I:234:ARG:NH1	2:J:10:TYR:HB3	2.32	0.44
1:C:162:GLY:O	1:C:166:GLU:HG2	2.16	0.44
1:F:242:GLN:NE2	2:G:11:SER:O	2.47	0.44
1:I:117:ALA:HB2	2:J:60:TRP:CE2	2.52	0.44
1:I:206:LEU:HB3	1:I:242:GLN:HE21	1.82	0.44
1:C:204:TRP:HZ2	2:D:99:MET:HB3	1.83	0.44
1:C:219:LEU:HD13	1:C:257:TYR:CZ	2.53	0.44
1:F:153:ALA:O	1:F:157[B]:ARG:HB2	2.17	0.44
2:B:83:LYS:HG2	2:B:90:PRO:HG3	1.99	0.43
1:F:22:TYR:CE2	1:F:24:GLU:HG3	2.53	0.43
1:F:169:ARG:O	1:F:173:LYS:HG2	2.17	0.43
2:J:24:ASN:HD22	2:J:67:HIS:HB3	1.83	0.43
1:A:268:GLU:HB3	6:A:442:HOH:O	2.17	0.43
2:G:79:ALA:HB2	2:G:94:TYR:CD1	2.54	0.43
1:F:238:ASP:HB3	1:F:240:THR:HG23	2.00	0.43
1:C:130:LEU:O	1:C:157:ARG:NH1	2.46	0.43
1:F:137:ASP:O	1:F:141:GLN:HG3	2.19	0.43
2:D:17:ASN:HA	2:D:72:PRO:O	2.19	0.43
1:F:99:ALA:HB3	3:H:3:PRO:HG3	1.99	0.43
1:A:138:MET:HE3	6:A:434:HOH:O	2.19	0.42
1:F:224:LEU:O	1:F:228:MET:HB2	2.19	0.42
1:I:95:LEU:HD23	1:I:117:ALA:O	2.19	0.42
1:A:105:SER:C	1:A:107:GLY:H	2.23	0.42
1:C:35:ARG:HG3	1:C:48:ARG:HG3	2.01	0.42
1:I:218:GLN:HG2	1:I:223:GLU:HA	2.01	0.42
1:I:55:GLU:OE2	1:I:170:ARG:NH1	2.52	0.42
2:B:16:GLU:HB2	2:B:19:LYS:HG3	2.02	0.42
1:C:109:LEU:HD23	1:C:109:LEU:HA	1.80	0.42
1:C:234:ARG:NE	1:C:242:GLN:OE1	2.48	0.42
1:C:41:GLU:OE1	1:C:41:GLU:N	2.31	0.42
1:C:204:TRP:CZ2	2:D:99:MET:HB3	2.55	0.42
1:F:238:ASP:OD1	5:F:304:GOL:H11	2.20	0.42
1:C:111:ARG:CZ	1:C:128:GLU:HG2	2.49	0.41
1:C:228:MET:HA	1:C:246:SER:O	2.19	0.41
1:A:7:TYR:CE2	3:P:2:GLY:HA2	2.54	0.41
2:D:96:ASP:O	2:D:99:MET:HB2	2.20	0.41
1:A:183:ASP:HA	1:A:184:PRO:HD3	1.94	0.41

Continued on next page...

Continued from previous page...

Atom-1	Atom-2	Interatomic distance (Å)	Clash overlap (Å)
1:C:117:ALA:HB2	2:D:60:TRP:CE2	2.55	0.41
2:B:50:GLU:HB2	2:B:67:HIS:CE1	2.55	0.41
1:C:95:LEU:HD23	1:C:95:LEU:HA	1.87	0.41
1:A:176:ASN:OD1	1:A:180:LEU:HD12	2.21	0.41
2:G:48:LYS:HA	2:G:48:LYS:HD2	1.74	0.41
1:A:266:LEU:HD13	1:A:270:LEU:HG	2.03	0.41
2:J:17:ASN:HA	2:J:72:PRO:O	2.21	0.41
1:A:133:TRP:HB2	1:A:144:ARG:HG3	2.03	0.40
1:F:218:GLN:HE21	1:F:223:GLU:HG2	1.85	0.40
1:I:27:TYR:CE1	1:I:32:GLU:HB2	2.55	0.40
2:D:12:ARG:H	2:D:12:ARG:HG2	1.64	0.40
1:I:184:PRO:HA	1:I:185:PRO:HD3	1.99	0.40
1:A:6:ARG:HD2	6:A:417:HOH:O	2.22	0.40
1:I:4:SER:HB3	1:I:102:ASP:OD1	2.22	0.40

All (1) symmetry-related close contacts are listed below. The label for Atom-2 includes the symmetry operator and encoded unit-cell translations to be applied.

Atom-1	Atom-2	Interatomic distance (Å)	Clash overlap (Å)
1:A:273:ARG:NH2	1:C:53:GLU:OE1[1_445]	2.16	0.04

5.3 Torsion angles [i](#)

5.3.1 Protein backbone [i](#)

In the following table, the Percentiles column shows the percent Ramachandran outliers of the chain as a percentile score with respect to all X-ray entries followed by that with respect to entries of similar resolution.

The Analysed column shows the number of residues for which the backbone conformation was analysed, and the total number of residues.

Mol	Chain	Analysed	Favoured	Allowed	Outliers	Percentiles
1	A	271/275 (98%)	261 (96%)	9 (3%)	1 (0%)	30 34
1	C	271/275 (98%)	258 (95%)	12 (4%)	1 (0%)	30 34
1	F	274/275 (100%)	261 (95%)	11 (4%)	2 (1%)	19 20
1	I	258/275 (94%)	235 (91%)	20 (8%)	3 (1%)	11 10
2	B	98/100 (98%)	91 (93%)	6 (6%)	1 (1%)	13 13

Continued on next page...

Continued from previous page...

Mol	Chain	Analysed	Favoured	Allowed	Outliers	Percentiles	
2	D	98/100 (98%)	94 (96%)	4 (4%)	0	100	100
2	G	98/100 (98%)	96 (98%)	2 (2%)	0	100	100
2	J	98/100 (98%)	95 (97%)	2 (2%)	1 (1%)	13	13
3	E	7/9 (78%)	5 (71%)	2 (29%)	0	100	100
3	H	7/9 (78%)	5 (71%)	2 (29%)	0	100	100
3	K	7/9 (78%)	7 (100%)	0	0	100	100
3	P	7/9 (78%)	7 (100%)	0	0	100	100
All	All	1494/1536 (97%)	1415 (95%)	70 (5%)	9 (1%)	22	24

All (9) Ramachandran outliers are listed below:

Mol	Chain	Res	Type
1	I	225	THR
1	C	226	GLN
1	F	106	ASP
1	I	224	LEU
2	B	2	GLN
2	J	47	PRO
1	A	29	ASP
1	F	275	GLY
1	I	238	ASP

5.3.2 Protein sidechains [i](#)

In the following table, the Percentiles column shows the percent sidechain outliers of the chain as a percentile score with respect to all X-ray entries followed by that with respect to entries of similar resolution.

The Analysed column shows the number of residues for which the sidechain conformation was analysed, and the total number of residues.

Mol	Chain	Analysed	Rotameric	Outliers	Percentiles	
1	A	228/230 (99%)	223 (98%)	5 (2%)	47	59
1	C	229/230 (100%)	221 (96%)	8 (4%)	31	40
1	F	230/230 (100%)	220 (96%)	10 (4%)	25	31
1	I	200/230 (87%)	195 (98%)	5 (2%)	42	53
2	B	93/94 (99%)	92 (99%)	1 (1%)	70	81

Continued on next page...

Continued from previous page...

Mol	Chain	Analysed	Rotameric	Outliers	Percentiles	
2	D	91/94 (97%)	89 (98%)	2 (2%)	47	59
2	G	93/94 (99%)	88 (95%)	5 (5%)	18	21
2	J	91/94 (97%)	90 (99%)	1 (1%)	70	81
3	E	6/6 (100%)	6 (100%)	0	100	100
3	H	6/6 (100%)	6 (100%)	0	100	100
3	K	6/6 (100%)	5 (83%)	1 (17%)	2	1
3	P	6/6 (100%)	6 (100%)	0	100	100
All	All	1279/1320 (97%)	1241 (97%)	38 (3%)	36	46

All (38) residues with a non-rotameric sidechain are listed below:

Mol	Chain	Res	Type
1	A	45	TYR
1	A	222	GLU
1	A	225	THR
1	A	242	GLN
1	A	271	THR
2	B	81	ARG
1	C	4	SER
1	C	6	ARG
1	C	45	TYR
1	C	50	ARG
1	C	103	VAL
1	C	222	GLU
1	C	224	LEU
1	C	268	GLU
2	D	12	ARG
2	D	54	MET
1	F	45	TYR
1	F	46	GLU
1	F	104	GLU
1	F	109	LEU
1	F	155	ARG
1	F	191	HIS
1	F	206	LEU
1	F	242	GLN
1	F	255	GLN
1	F	276	LYS
2	G	0	MET
2	G	53	ASP

Continued on next page...

Continued from previous page...

Mol	Chain	Res	Type
2	G	57	SER
2	G	70	PHE
2	G	97	ARG
1	I	45	TYR
1	I	95	LEU
1	I	105	SER
1	I	214	THR
1	I	258	THR
2	J	0	MET
3	K	9	VAL

Sometimes sidechains can be flipped to improve hydrogen bonding and reduce clashes. All (7) such sidechains are listed below:

Mol	Chain	Res	Type
1	A	218	GLN
2	B	67	HIS
2	D	24	ASN
1	F	115	GLN
1	F	218	GLN
1	I	242	GLN
2	J	24	ASN

5.3.3 RNA [i](#)

There are no RNA molecules in this entry.

5.4 Non-standard residues in protein, DNA, RNA chains [i](#)

There are no non-standard protein/DNA/RNA residues in this entry.

5.5 Carbohydrates [i](#)

There are no oligosaccharides in this entry.

5.6 Ligand geometry [i](#)

9 ligands are modelled in this entry.

In the following table, the Counts columns list the number of bonds (or angles) for which Mogul statistics could be retrieved, the number of bonds (or angles) that are observed in the model and the number of bonds (or angles) that are defined in the Chemical Component Dictionary. The Link column lists molecule types, if any, to which the group is linked. The Z score for a bond length (or angle) is the number of standard deviations the observed value is removed from the expected value. A bond length (or angle) with $|Z| > 2$ is considered an outlier worth inspection. RMSZ is the root-mean-square of all Z scores of the bond lengths (or angles).

Mol	Type	Chain	Res	Link	Bond lengths			Bond angles		
					Counts	RMSZ	# Z > 2	Counts	RMSZ	# Z > 2
4	EDO	B	102	-	3,3,3	0.56	0	2,2,2	0.08	0
4	EDO	D	101	-	3,3,3	0.44	0	2,2,2	0.44	0
5	GOL	F	304	-	5,5,5	0.40	0	5,5,5	0.88	0
4	EDO	F	302	-	3,3,3	0.34	0	2,2,2	0.60	0
5	GOL	F	301	-	5,5,5	0.32	0	5,5,5	0.39	0
4	EDO	F	303	-	3,3,3	0.47	0	2,2,2	0.41	0
4	EDO	I	301	-	3,3,3	0.41	0	2,2,2	0.84	0
4	EDO	A	301	-	3,3,3	0.32	0	2,2,2	0.62	0
4	EDO	B	101	-	3,3,3	0.44	0	2,2,2	0.51	0

In the following table, the Chirals column lists the number of chiral outliers, the number of chiral centers analysed, the number of these observed in the model and the number defined in the Chemical Component Dictionary. Similar counts are reported in the Torsion and Rings columns. '-' means no outliers of that kind were identified.

Mol	Type	Chain	Res	Link	Chirals	Torsions	Rings
4	EDO	B	102	-	-	0/1/1/1	-
4	EDO	D	101	-	-	0/1/1/1	-
5	GOL	F	304	-	-	0/4/4/4	-
4	EDO	F	302	-	-	1/1/1/1	-
5	GOL	F	301	-	-	0/4/4/4	-
4	EDO	F	303	-	-	1/1/1/1	-
4	EDO	I	301	-	-	0/1/1/1	-
4	EDO	A	301	-	-	0/1/1/1	-
4	EDO	B	101	-	-	0/1/1/1	-

There are no bond length outliers.

There are no bond angle outliers.

There are no chirality outliers.

All (2) torsion outliers are listed below:

Mol	Chain	Res	Type	Atoms
4	F	302	EDO	O1-C1-C2-O2

Continued on next page...

Continued from previous page...

Mol	Chain	Res	Type	Atoms
4	F	303	EDO	O1-C1-C2-O2

There are no ring outliers.

3 monomers are involved in 6 short contacts:

Mol	Chain	Res	Type	Clashes	Symm-Clashes
5	F	304	GOL	2	0
4	F	302	EDO	2	0
4	I	301	EDO	2	0

5.7 Other polymers [i](#)

There are no such residues in this entry.

5.8 Polymer linkage issues [i](#)

There are no chain breaks in this entry.

6 Fit of model and data [i](#)

6.1 Protein, DNA and RNA chains [i](#)

In the following table, the column labelled '#RSRZ > 2' contains the number (and percentage) of RSRZ outliers, followed by percent RSRZ outliers for the chain as percentile scores relative to all X-ray entries and entries of similar resolution. The OWAB column contains the minimum, median, 95th percentile and maximum values of the occupancy-weighted average B-factor per residue. The column labelled 'Q < 0.9' lists the number of (and percentage) of residues with an average occupancy less than 0.9.

Mol	Chain	Analysed	<RSRZ>	#RSRZ>2	OWAB(Å ²)	Q<0.9
1	A	273/275 (99%)	0.12	9 (3%) 49 55	23, 45, 78, 99	0
1	C	273/275 (99%)	0.08	15 (5%) 32 37	21, 41, 88, 136	0
1	F	275/275 (100%)	0.14	8 (2%) 54 60	20, 44, 82, 116	1 (0%)
1	I	266/275 (96%)	1.33	70 (26%) 2 2	29, 78, 116, 144	3 (1%)
2	B	99/100 (99%)	-0.26	2 (2%) 64 69	15, 32, 58, 89	1 (1%)
2	D	100/100 (100%)	0.23	6 (6%) 29 33	26, 51, 81, 107	0
2	G	100/100 (100%)	-0.12	3 (3%) 52 58	25, 38, 61, 94	0
2	J	100/100 (100%)	0.83	11 (11%) 12 14	30, 68, 105, 117	0
3	E	9/9 (100%)	0.03	0 100 100	30, 32, 39, 40	0
3	H	9/9 (100%)	0.22	0 100 100	33, 39, 45, 48	0
3	K	9/9 (100%)	0.44	0 100 100	38, 43, 56, 64	0
3	P	9/9 (100%)	-0.14	0 100 100	26, 31, 39, 46	0
All	All	1522/1536 (99%)	0.34	124 (8%) 19 23	15, 47, 101, 144	5 (0%)

All (124) RSRZ outliers are listed below:

Mol	Chain	Res	Type	RSRZ
1	I	225	THR	8.2
1	I	104	GLU	7.3
1	C	225	THR	4.8
1	I	52	ILE	4.6
1	I	177	ALA	4.3
1	I	270	LEU	4.2
1	C	107	GLY	3.9
1	I	275	GLY	3.9
1	A	220	ASN	3.9
1	F	105	SER	3.9
1	I	227	GLU	3.8

Continued on next page...

Continued from previous page...

Mol	Chain	Res	Type	RSRZ
1	I	219	LEU	3.7
1	I	250	PRO	3.7
1	F	275	GLY	3.7
1	I	197	GLY	3.7
1	I	237	GLY	3.7
1	C	224	LEU	3.6
1	I	106	ASP	3.5
1	F	178	THR	3.5
1	I	175	GLY	3.4
2	D	53	ASP	3.4
1	I	215	LEU	3.4
1	I	223	GLU	3.4
1	I	226	GLN	3.2
1	I	58	GLU	3.2
1	I	27	TYR	3.2
1	I	274	TRP	3.1
1	I	105	SER	3.1
1	C	227	GLU	3.1
1	I	222	GLU	3.1
2	B	53	ASP	3.1
1	I	51	TRP	3.1
2	D	0	MET	3.0
1	I	199	VAL	3.0
1	I	224	LEU	3.0
1	I	251	LEU	3.0
1	I	98	MET	3.0
1	I	231	VAL	3.0
2	J	10	TYR	3.0
1	I	230	LEU	3.0
2	B	1	ILE	2.9
1	I	198	ASP	2.9
1	A	138	MET	2.9
1	F	276	LYS	2.9
1	I	182	THR	2.8
1	I	29	ASP	2.8
1	I	191	HIS	2.8
1	I	258	THR	2.7
1	I	264	GLU	2.7
2	J	14	PRO	2.7
1	I	211	ALA	2.7
1	I	54	GLN	2.7
1	I	5	LEU	2.7

Continued on next page...

Continued from previous page...

Mol	Chain	Res	Type	RSRZ
2	J	12	ARG	2.7
1	I	194	ARG	2.6
1	I	180	LEU	2.6
2	D	52	SER	2.6
1	A	225	THR	2.6
1	C	195	PRO	2.6
1	I	193	ARG	2.6
1	C	221	GLY	2.6
2	G	0	MET	2.6
1	I	200	THR	2.6
1	I	60	TRP	2.6
1	I	28	VAL	2.5
1	I	248	VAL	2.5
1	A	224	LEU	2.5
2	G	1	ILE	2.5
1	A	106	ASP	2.5
2	J	53	ASP	2.5
1	F	220	ASN	2.5
1	I	176	ASN	2.4
1	I	171	TYR	2.4
2	D	98	ASP	2.4
1	C	255	GLN	2.4
1	C	273	ARG	2.4
1	I	167	TRP	2.4
1	I	136	ALA	2.4
1	I	239	GLY	2.4
1	C	236	ALA	2.4
1	I	110	LEU	2.4
1	I	57	PRO	2.3
1	F	238	ASP	2.3
1	I	213	ILE	2.3
1	A	44	ARG	2.3
1	C	108	ARG	2.3
2	D	54	MET	2.3
1	I	178	THR	2.3
1	I	256	LYS	2.3
1	I	257	TYR	2.3
2	J	13	HIS	2.3
1	C	237	GLY	2.3
1	I	247	VAL	2.3
1	I	3	HIS	2.2
1	C	251	LEU	2.2

Continued on next page...

Continued from previous page...

Mol	Chain	Res	Type	RSRZ
1	C	106	ASP	2.2
1	I	160	LEU	2.2
1	I	255	GLN	2.2
2	J	19	LYS	2.2
2	J	99	MET	2.2
1	I	262	GLU	2.2
1	I	50	ARG	2.2
1	I	168	LEU	2.2
2	J	48	LYS	2.2
1	A	105	SER	2.1
1	I	254	GLU	2.1
1	F	166	GLU	2.1
1	I	181	ARG	2.1
2	J	22	ILE	2.1
2	D	48	LYS	2.1
1	I	236	ALA	2.1
1	A	227	GLU	2.1
1	C	29	ASP	2.1
2	G	53	ASP	2.1
2	J	1	ILE	2.1
1	F	110	LEU	2.1
1	I	179	LEU	2.1
1	I	201	LEU	2.1
2	J	75	THR	2.1
1	C	223	GLU	2.0
1	I	33	PHE	2.0
1	A	221	GLY	2.0
1	I	192	HIS	2.0
1	I	210	PRO	2.0

6.2 Non-standard residues in protein, DNA, RNA chains [i](#)

There are no non-standard protein/DNA/RNA residues in this entry.

6.3 Carbohydrates [i](#)

There are no monosaccharides in this entry.

6.4 Ligands [i](#)

In the following table, the Atoms column lists the number of modelled atoms in the group and the number defined in the chemical component dictionary. The B-factors column lists the minimum, median, 95th percentile and maximum values of B factors of atoms in the group. The column labelled 'Q< 0.9' lists the number of atoms with occupancy less than 0.9.

Mol	Type	Chain	Res	Atoms	RSCC	RSR	B-factors(Å ²)	Q<0.9
5	GOL	F	301	6/6	0.73	0.17	48,50,54,56	0
5	GOL	F	304	6/6	0.79	0.18	36,43,53,57	0
4	EDO	D	101	4/4	0.81	0.16	45,47,55,63	0
4	EDO	F	303	4/4	0.86	0.13	45,48,48,49	0
4	EDO	I	301	4/4	0.88	0.13	18,21,36,46	0
4	EDO	B	102	4/4	0.89	0.11	25,29,33,36	0
4	EDO	F	302	4/4	0.90	0.11	28,30,34,36	0
4	EDO	B	101	4/4	0.95	0.08	34,37,42,43	0
4	EDO	A	301	4/4	0.96	0.09	25,26,37,37	0

6.5 Other polymers [i](#)

There are no such residues in this entry.